

#	Change	Date

Architect: \_\_\_\_\_ Date: \_\_\_\_\_  
 Engineer: \_\_\_\_\_ Date: \_\_\_\_\_  
 Contractor: \_\_\_\_\_ Date: \_\_\_\_\_  
 Designed by: \_\_\_\_\_  
 Software by: \_\_\_\_\_  
 Checked by: \_\_\_\_\_

JOB NUMBER: ANG CIV ENG / M0600027  
 FILE NAME: MZ3.mz2  
 SHEET NO.: 1 OF 3

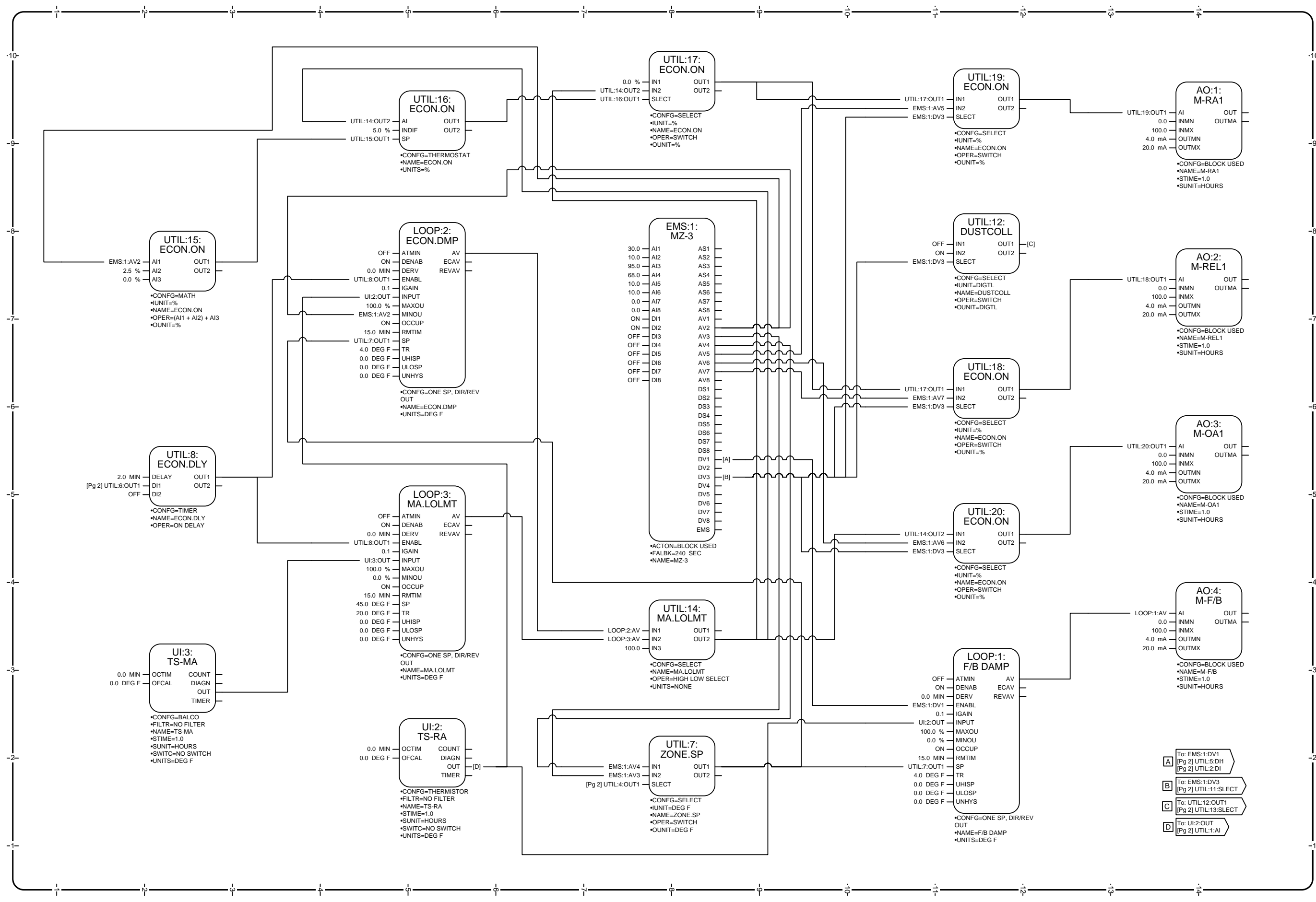

- A To: EMS:1:DV1  
[Pg 2] UTIL:5:DI1  
[Pg 2] UTIL:2:DI
- B To: EMS:1:DV3  
[Pg 2] UTIL:11:SELECT
- C To: UTIL:12:OUT1  
[Pg 2] UTIL:13:SELECT
- D To: UI:2:OUT  
[Pg 2] UTIL:1:AI

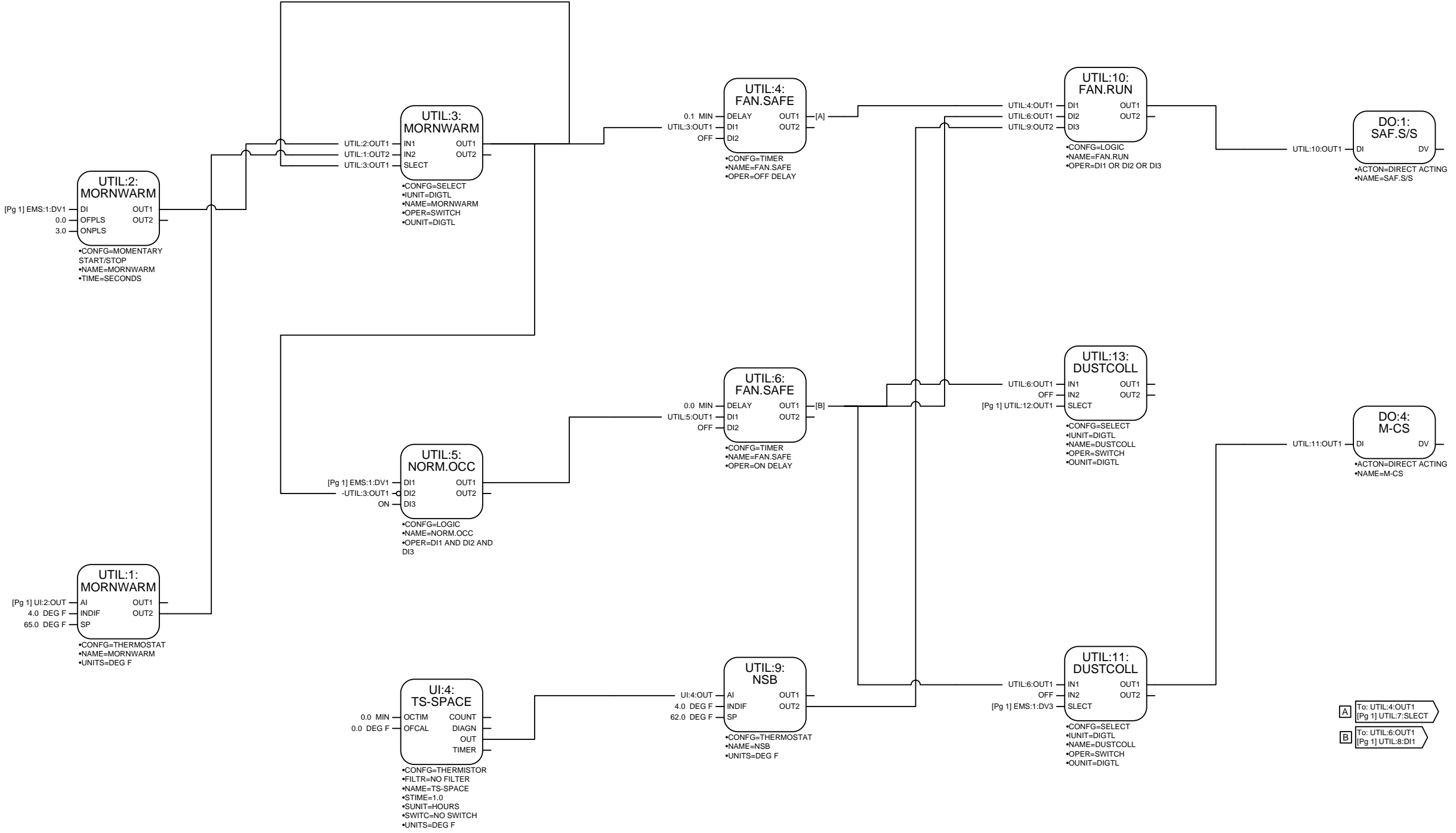

Revisions	
#	Change:

Architect: \_\_\_\_\_ Date: \_\_\_\_\_  
 Engineer: \_\_\_\_\_ Date: \_\_\_\_\_  
 Contractor: \_\_\_\_\_ Date: \_\_\_\_\_  
 Designed by: \_\_\_\_\_  
 Software by: \_\_\_\_\_  
 Checked by: \_\_\_\_\_

JOB NUMBER: ANG CIV ENG / M0600027  
 FILE NAME: MZ3.mz2  
 SHEET NO.: 2 OF 3  
 MZ3

- A** To: UTIL:4:OUT1  
[Pg 1] UTIL:7:S/ELECT
- B** To: UTIL:6:OUT1  
[Pg 1] UTIL:8:DI1



Revisions	
#	Date:

Architect: \_\_\_\_\_ Date: \_\_\_\_\_  
 Engineer: \_\_\_\_\_ Date: \_\_\_\_\_  
 Contractor: \_\_\_\_\_ Date: \_\_\_\_\_  
 Designed by: \_\_\_\_\_  
 Software by: \_\_\_\_\_  
 Checked by: \_\_\_\_\_

JOB NUMBER: ANG CIV ENG / M0600027  
 FILE NAME: MZ3.mz2  
 SHEET NO.: MZ3  
 3 OF 3

Block Name	Pg Name	Pg #	Loc (X,Y)
AO:1:M-RA1	PAGE #1	1	(14, 10)
AO:2:M-REL1	PAGE #1	1	(14, 8)
AO:3:M-OA1	PAGE #1	1	(14, 6)
AO:4:M-F/B	PAGE #1	1	(14, 4)
DO:1:SAF.S/S	PAGE #2	2	(14, 8)
DO:4:M-CS	PAGE #2	2	(14, 6)
EMS:1:MZ-3	PAGE #1	1	(8, 8)
LOOP:1:F/B DAMP	PAGE #1	1	(12, 3)
LOOP:2:ECON.DMP	PAGE #1	1	(5, 8)
LOOP:3:MA.LOLMT	PAGE #1	1	(5, 5)
UI:1:TS-SA	PAGE #3	3	(5, 8)
UI:2:TS-RA	PAGE #1	1	(5, 2)
UI:3:TS-MA	PAGE #1	1	(2, 3)
UI:4:TS-SPACE	PAGE #2	2	(5, 3)
UI:5:CS-SF	PAGE #3	3	(5, 4)
UTIL:1:MORNWARM	PAGE #2	2	(2, 4)
UTIL:2:MORNWARM	PAGE #2	2	(2, 8)
UTIL:3:MORNWARM	PAGE #2	2	(5, 8)
UTIL:4:FAN.SAFE	PAGE #2	2	(8, 9)
UTIL:5:NORM.OCC	PAGE #2	2	(5, 5)
UTIL:6:FAN.SAFE	PAGE #2	2	(8, 6)
UTIL:7:ZONE.SP	PAGE #1	1	(8, 2)
UTIL:8:ECON.DLY	PAGE #1	1	(2, 6)
UTIL:9:NSB	PAGE #2	2	(8, 3)
UTIL:10:FAN.RUN	PAGE #2	2	(11, 9)
UTIL:11:DUSTCOLL	PAGE #2	2	(11, 3)
UTIL:12:DUSTCOLL	PAGE #1	1	(12, 8)
UTIL:13:DUSTCOLL	PAGE #2	2	(11, 6)
UTIL:14:MA.LOLMT	PAGE #1	1	(8, 4)
UTIL:15:ECON.ON	PAGE #1	1	(2, 8)
UTIL:16:ECON.ON	PAGE #1	1	(5, 10)
UTIL:17:ECON.ON	PAGE #1	1	(8, 10)
UTIL:18:ECON.ON	PAGE #1	1	(12, 7)
UTIL:19:ECON.ON	PAGE #1	1	(12, 10)
UTIL:20:ECON.ON	PAGE #1	1	(12, 5)

Block Name	Output	Pointed To By
EMS:1:MZ-3	DV1	LOOP:1:F/B DAMP:ENABL
	AV2	LOOP:2:ECON.DMP:MINOU
	DV3	UTIL:11:DUSTCOLL:SLECT
		UTIL:12:DUSTCOLL:SLECT
	AV2	UTIL:15:ECON.ON:AI1
	AV7	UTIL:18:ECON.ON:IN2
	DV3	UTIL:18:ECON.ON:SLECT
	AV5	UTIL:19:ECON.ON:IN2
	DV3	UTIL:19:ECON.ON:SLECT
	DV1	UTIL:2:MORNWARM:DI
	AV6	UTIL:20:ECON.ON:IN2
	DV3	UTIL:20:ECON.ON:SLECT
	DV1	UTIL:5:NORM.OCC:DI1
	AV4	UTIL:7:ZONE.SP:IN1
	AV3	UTIL:7:ZONE.SP:IN2
LOOP:1:F/B DAMP	AV	AO:4:M-F/B:AI
LOOP:2:ECON.DMP	AV	UTIL:14:MA.LOLMT:IN1
LOOP:3:MA.LOLMT	AV	UTIL:14:MA.LOLMT:IN2
UI:2:TS-RA	OUT	LOOP:1:F/B DAMP:INPUT
		LOOP:2:ECON.DMP:INPUT
		UTIL:1:MORNWARM:AI
UI:3:TS-MA	OUT	LOOP:3:MA.LOLMT:INPUT
UI:4:TS-SPACE	OUT2	UTIL:9:NSB:AI
UTIL:1:MORNWARM	OUT2	UTIL:3:MORNWARM:IN2
UTIL:2:MORNWARM	OUT1	UTIL:3:MORNWARM:IN1
UTIL:3:MORNWARM	OUT1	UTIL:3:MORNWARM:SLECT
		UTIL:4:FAN.SAFE:DI1
		UTIL:5:NORM.OCC:DI2
UTIL:4:FAN.SAFE	OUT1	UTIL:10:FAN.RUN:DI1
		UTIL:7:ZONE.SP:SLECT
UTIL:5:NORM.OCC	OUT1	UTIL:6:FAN.SAFE:DI1
UTIL:6:FAN.SAFE	OUT1	UTIL:10:FAN.RUN:DI2
		UTIL:11:DUSTCOLL:IN1
		UTIL:13:DUSTCOLL:IN1
		UTIL:8:ECON.DLY:DI1
UTIL:7:ZONE.SP	OUT1	LOOP:1:F/B DAMP:SP
		LOOP:2:ECON.DMP:SP
UTIL:8:ECON.DLY	OUT1	LOOP:2:ECON.DMP:ENABL
		LOOP:3:MA.LOLMT:ENABL
UTIL:9:NSB	OUT2	UTIL:10:FAN.RUN:DI3
UTIL:10:FAN.RUN	OUT1	DO:1:SAF.S/S:DI
UTIL:11:DUSTCOLL	OUT1	DO:4:M-CS:DI
UTIL:12:DUSTCOLL	OUT1	UTIL:13:DUSTCOLL:SLECT
UTIL:14:MA.LOLMT	OUT2	UTIL:16:ECON.ON:AI
		UTIL:17:ECON.ON:IN2
UTIL:15:ECON.ON	OUT1	UTIL:20:ECON.ON:IN1
UTIL:16:ECON.ON	OUT1	UTIL:16:ECON.ON:SP
UTIL:17:ECON.ON	OUT1	UTIL:17:ECON.ON:SLECT
		UTIL:18:ECON.ON:IN1
		UTIL:19:ECON.ON:IN1
UTIL:18:ECON.ON	OUT1	AO:2:M-REL1:AI
UTIL:19:ECON.ON	OUT1	AO:1:M-RA1:AI
UTIL:20:ECON.ON	OUT1	AO:3:M-OA1:AI

